

YOU WILL NOT ONLY FEEL THE DIFFERENCE BUT SEE THE RESULTS!

1-3.5 TON ELECTRIC FORKLIFT PERFORMANCE PARAMETER

Model			Unit	CPD10	CPD15	CPD20	CPD25	CPD30
Module				Curtis Control	Curtis Control	Curtis Control	Curtis Control	Curtis Control
Rated Capacity			kg	1000	1500	2000	2500	3000
Load Center			mm	500	500	500	500	500
Operator Type				SEATED	SEATED	SEATED	SEATED	SEATED
Lift height			mm	3000	3000	3000	3000	3000
Free Lift			mm	125	125	160	160	155
Tilt angle (Front/Rear)				6° / 12°	6° / 12°	6° / 12°	6° / 12°	6° / 12°
Overhead Length		without fork	mm	1975	1980	2360	2390	2565
		with fork	mm	2895	2900	3325	3460	3635
Overhead Width		outboard	mm	1070	1070	1180	1180	1255
		frame	mm	1070	1070	1150	1150	1225
Height		Mast Drop	mm	1995	1995	1990	1990	2065
		Front Wheel Overhead	mm	2080	2080	2180	2180	2200
Minimum Turning radius			mm	1950	1950	2300	2320	2250
Overhang (front)			mm	410	410	485	485	498
Overhang (back)			mm	319	349	395	425	/
Inside Cab height			mm	1015	1015	1015	1015	1005
Minimum Intersecting aisle			mm	1850	1885	2320	2320	2400
Speed	Max. Driving Speed	With Load	km/h	13,5	13	11,5	11	13
		Without Load	km/h	15	15	15	15	15
	Lifting	With Load	km/h	235	235	272	257	280
		Without Load	km/h	300	300	430	427	360
	Lowering	With Load	mm/s	460	460	460	460	475
		Without Load	mm/s	430	430	430	430	425
Max. Drawbar Pull		With Load/Without Load	kN	18.5/8.9	18.5/8.9	11.2/9.2	11.2/8.6	11.2/10.2
Max. Gradeability (Loaded)		With Load/Without Load	% (fan)	19/15	19/15	19/10	19/10	20/10
Weight			kg	2600	2900	4150	4460	4960
Tyre	Specifications	Front	mm	6.50-10-10PR	6.50-0-10PR	7.00-12-12PR	7.00-12-12PR	28x9-15-12PR
		Back	mm	5.00-8-10PR	5.00-8-10PR	6.00-9-10PR	6.00-9-10PR	6.50-10-10PR
Wheelbase			mm	1250	1250	1500	1500	1700
Tread		Front	mm	890	890	980	970	1000
		Back	mm	920	920	950	495	970
Turning Radius		Low-water mark (mast)	mm	105	105	80	84	125
		Frame	mm	110	110	125	130	140
Service Brake				HP	HP	HP	HP	HP
				MH	MH	MH	MH	MH
Battery	Voltage		V	48	48	48	48	80
	Capacity			400/480	400/480	620	620	500
Motor Running		Model		XQ-5T	XQ-5T	XQ-8-1T	XQ-8-1T	XQ-10T
Rated Output			kw/rpm	5	5	8	8	10
Transmission		Type		PS/M	PS/M	PS/M	PS/M	PS/M
Number of Speeds				1 / 1	1 / 1	1 / 1	1 / 1	1 / 1

CPD30

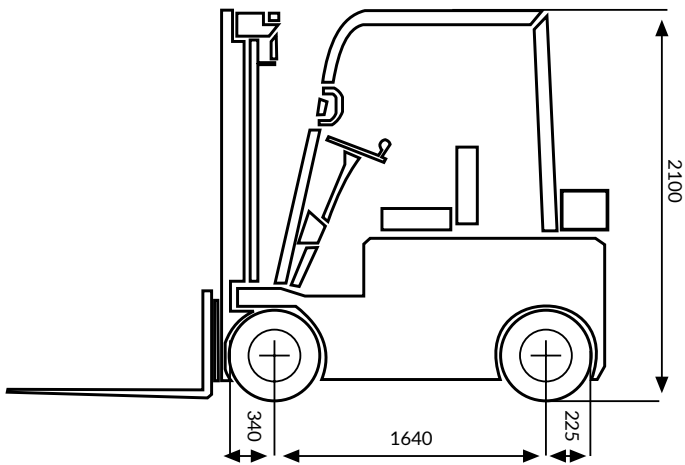

SIDE VIEW

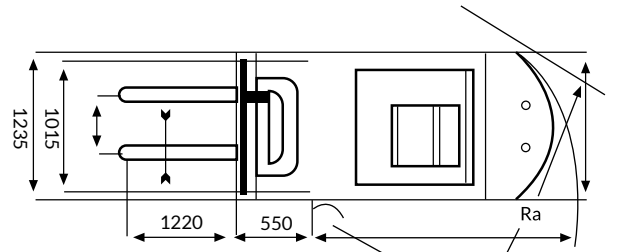

VERTICAL VIEW

LOAD CURVE

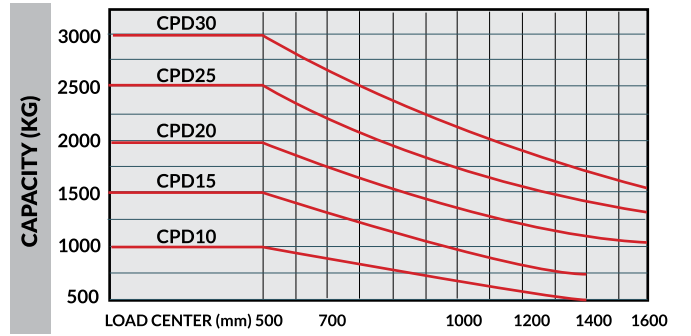

CPD10



CPD15



CPD25



CPD30